



航发机器人家族

OmniTurtle
麦克纳姆轮式全向车

灵活、浪漫、骑士精神



OmniRhino
差动舵轮式全向车

稳重、忠诚、果断



OmniTitan
A-Titan轮式全向车

忠厚、耐力、力大无穷



OmniAnt
转向舵轮式全向车

朴素、勤劳、持久生命力

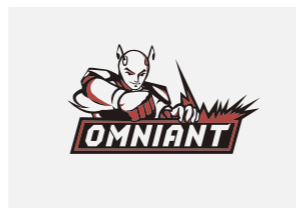

HANGFA航发用心做好机器人, 做一流企业, 做百年企业。

成都航发机器人有限公司

地址: 四川成都市郫都区, 成都现代工业港北区港北三路220号

电话: +86 028-87050289 / 87050379

传真: +86 028-87050289

手机: +86 183-8206-6160

邮箱: partner@hangfa.com

网址: www.hangfa.com



微信公众号



视频号

重载全向移动平台 产品手册

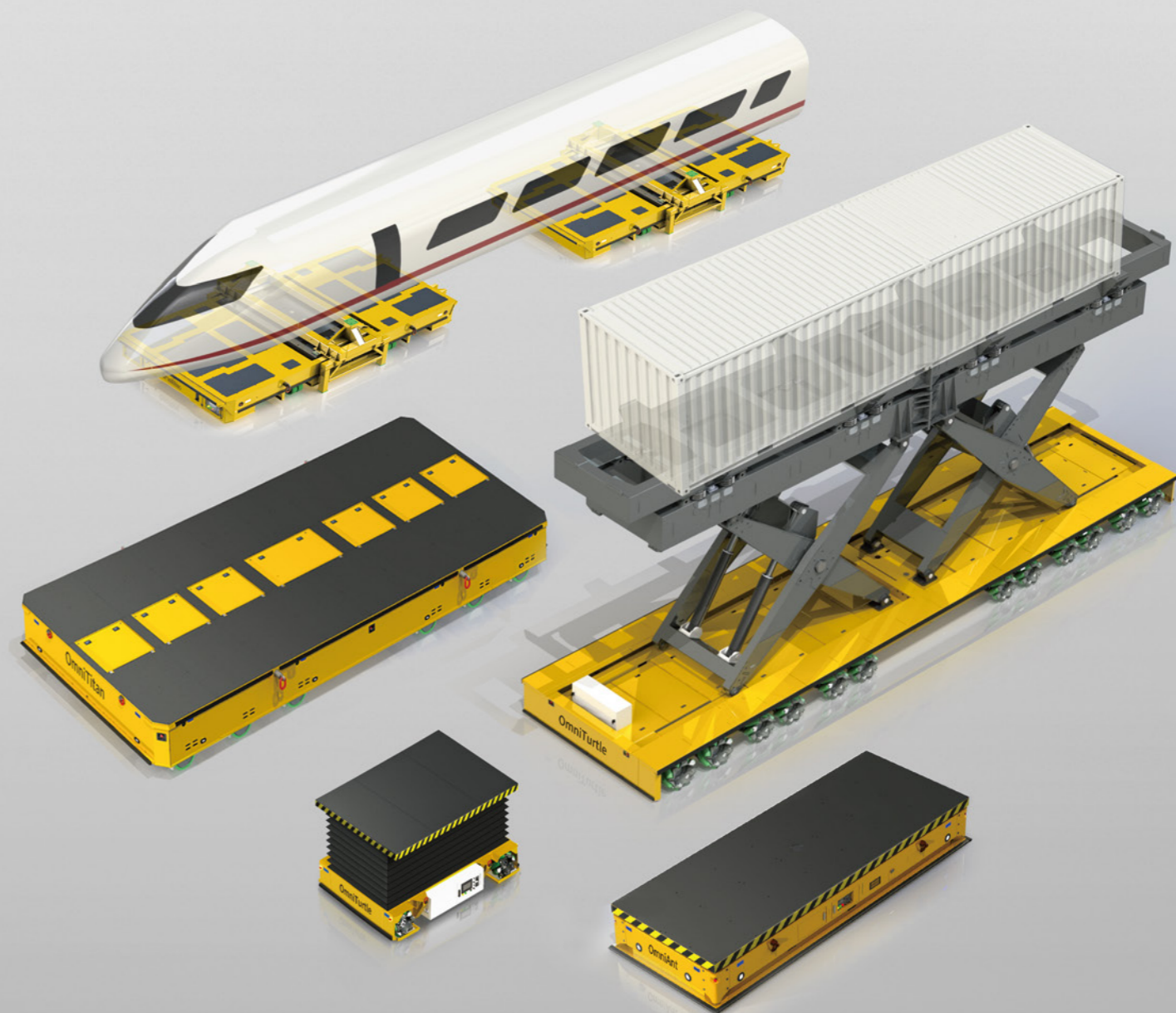



目录 Contents

航发机器人

公司介绍	01
荣誉和专利	03
我们的客户	05
重点产品	06

产品

OmniTurtle系列	07
OmniRhino系列	11
OmniTitan系列	13
OmniAnt系列	17
P系列	19
WH系列	21
全向轮/麦克纳姆轮	23
科研级平台	24

案例

风电	25
能源	27
轨道交通	29
航空航天、军工	30
重工	31
冶金和线缆	32
其它	33



Company Profile

公司介绍

成都航发机器人有限公司成立于2016年,是专业从事移动机器人、全向轮、非标自动化设备研发、生产、销售及服务的企业,总公司位于成都市郫都区,现有员工约300人,占地面积约100亩。公司通过了ISO9001、GJB9001等体系认证,获得了《国家高新技术企业》、《四川省专精特新企业》、《四川省瞪羚企业》等称号。现拥有各型专利四十余项,填补了国内多项空白。

经过多年的发展与积累,航发机器人已成为世界领先并极具影响力的重载移动机器人供应商,产品广泛应用于各行各业。包括轨道交通、航空航天、新能源、电力、工程机械、船舶、冶金、机械制造等行业。在北京、比利时、韩国、新加坡等地设有分支机构。



加工、组装、调试工厂



2025年新工厂



生产、办公环境

Honors and Patents

荣誉和专利

- 四川省瞪羚企业
- 国家高新技术企业
- 四川省专精特新企业
- 科技型中小企业
- ISO9001-质量管理体系认证
- GJB9001-武器装备质量管理体系认证
- 环境管理体系认证
- 职业健康安全管理体系认证
- 自主知识产权共计四十余项
- 软件企业
- 诚信经营示范单位
- 守合同重信用企业

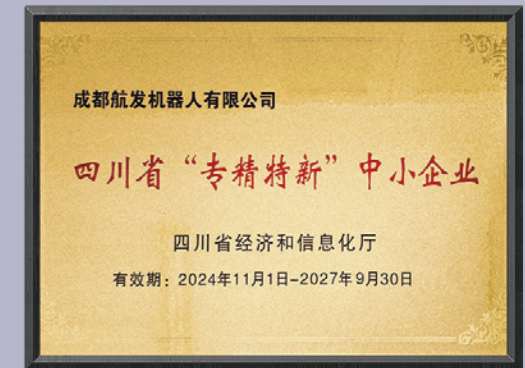

Our Customers

我们的客户

 国家能源集团 CHN ENERGY	 ENVISION Greenwich	 金风科技 GOLDWIND	 BOMAG® FAYAT GROUP
 GREE 格力	 CSSC 中国船舶集团有限公司 CHINA STATE SHIPBUILDING CORPORATION LIMITED	 COSCO SHIPPING	 COMAC 中国商飞
 特变电工 TBEA	 中国中车 CRRC	 AVIC 航空工业	 CASC 中国航天
 SANY	 航天欧华 WWW.O-WA.COM	 招商局集团 CHINA MERCHANTS GROUP	 CSR 时代新材
 双瑞 SUNRUI	 HE 哈电集团 Harbin Electric Corporation	 上柴动力	 中国建材
 XD 中国西电集团 CHINA XD GROUP	 国家核电 SNPTC	 中核集团 CNNC	 WEICHAI 潍柴
 CRCC 中国铁建	 Siyuan 思源电气	 ZOOMLION 中联重科	 XCMG 徐工集团
 哈电风能有限公司	 中国煤炭科工集团 CHINA COAL TECHNOLOGY & ENGINEERING GROUP	 中国国家铁路集团有限公司 CHINA RAILWAY	 中国电气装备 China Electrical Equipment 西安西电高压开关有限责任公司 XI'AN XD HIGH VOLTAGE APPARATUS CO., LTD.
 鞍钢集团 ANSTEEL	 浙江大学 ZHEJIANG UNIVERSITY	 北京理工大学 BEIJING INSTITUTE OF TECHNOLOGY	 太重集团 TZCO

Key Products

重点产品



OmniTurtle系列	
单车负载范围	0~100t
轮系形式	麦克纳姆轮
产品特点	可进行无间隙的运动动作切换、360°全向移动。可调精度优于1mm。联动时内应力可控，高响应性、高精度同步跟随。
典型应用场景	高效运输、对接、多车联动、酷炫应用

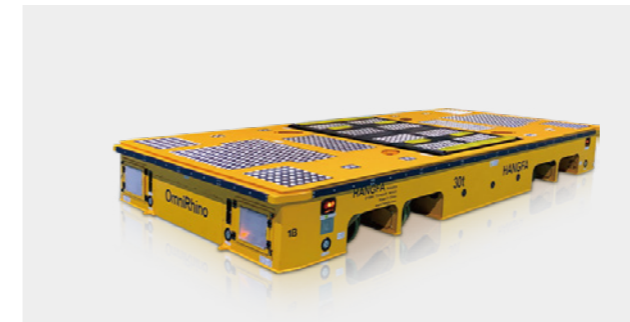

OmniRhino系列	
单车负载范围	0~120t
轮系形式	差动舵轮+万向轮
产品特点	越障、地面适应能力强。可支持公铁两用。部分车型联动内应力可控。
典型应用场景	高可靠性联动 比麦轮好的耐久性和地面适应能力



OmniTitan系列	
单车负载范围	0~500t
轮系形式	A-Titan差动舵轮
产品特点	超大负载
典型应用场景	超大型、超重型零件运输 较差的地面条件



OmniAnt系列	
单车负载范围	0~30t
轮系形式	转向舵轮+万向轮
产品特点	自动车、经济简单可靠 可进行高速运动
典型应用场景	高速型运输车、经济型AGV

OmniTurtle

麦克纳姆轮式全向车



HTB



HTL



HTT



HTM

- 单车0~100t承载能力
- 麦克纳姆轮驱动
- 轮系位置布置灵活/过轨能力/车架自顶升

- 特别适应精密对接应用，可调精度优于±1mm
- 无需切换时间，连续执行360°任意姿态变化动作

- 联动时的内应力可控
- 摆式悬挂/液压悬挂

运动模式



新能源汽车级锂电系统、免维护铅酸电池

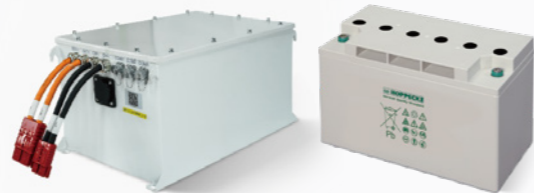

麦克纳姆轮

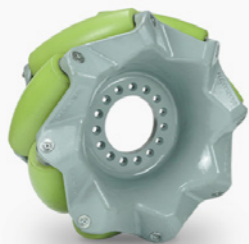

工业遥控器



产品外形

HTB
无升降

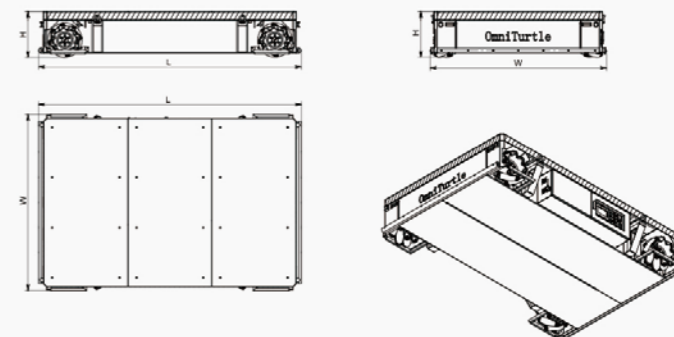

HTT
直动式升降

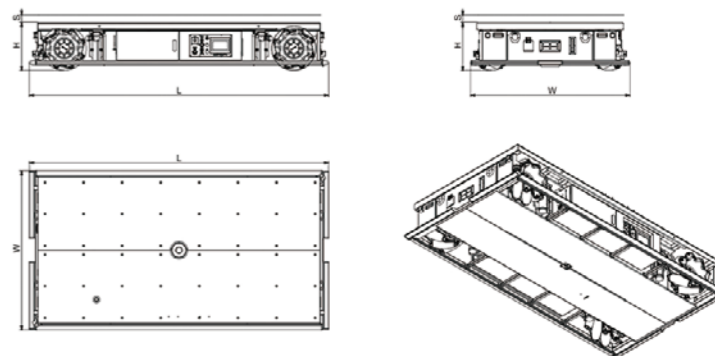

HTL
剪叉式升降

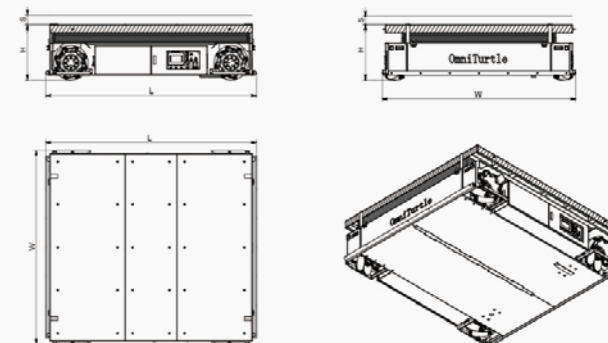

HTM
轮式升降

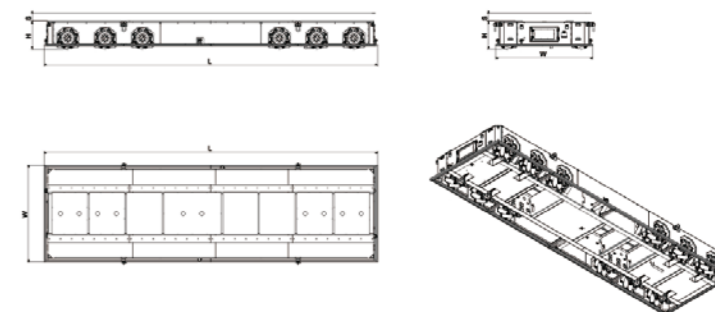

参数选型表											
产品规格											
型号	HT*1504	HT*2004	HT*20A04	HT*2504	HT*3104	HT*3604	HT*4004	HT*4008			
长mm (L)	800	900	900	1500	2000	2200	2400	3200			
宽mm (W)	600	600	700	1000	1300	1400	1500	1800			
HTB 无升降	高mm (H)	200	250	250	300	350	400	450			
	自重t	0.1	0.1	0.2	0.45	0.7	1.2	1.5	3		
	承载能力t	0.2	0.15	0.5	1	1.7	3	4.5	9		
HTT 直动式升降	高mm (Hmin)	-	-	350	400	450	500	550			
	升降行程mm (S)	-	-	60	100		120				
	举升速度mm/min	-	-	200							
	自重t	-	-	0.3	0.8	1.3	1.6	2.1	4		
	承载能力t	-	-	0.5	0.6	1.2	2.5	4	8		
HTL 剪叉式升降	高mm (Hmin)	-	-	-	400	450	500	550			
	升降行程mm (S)	-	-	-	600	800	800	900	600		
	举升速度mm/min	-	-	-	900						
	自重t	-	-	-	0.8	1.3	1.6	2.1	4		
	承载能力t	-	-	-	0.6	1.2	2.5	4	8		
HTM 轮系式升降	高mm (Hmin)	-	-	-	-	350	400	450			
	升降行程mm (S)	-	-	-	-	80	120	150			
	举升速度mm/min	-	-	-	-	200					
	自重t	-	-	-	-	1.2	1.4	1.8	3.4		
	承载能力t	-	-	-	-	1.2	2.5	4	8		
电源											
电池类型	三元锂电池			铅酸电池/磷酸铁锂电池							
电池容量	48V30AH			48V50AH	48V120AH		48V200AH				
典型续航时间	12h (根据工作制)										
满放充电时间	8h 铅酸电池/4h 锂电池 (快速充电可定制)										
充电器供电	AC220V/AC380V										
驱动单元											
车轮数量	4							8			
车轮直径mm	156.5	203.2	203.2	254	310	360	406.4				
车轮承载能力t	0.1	0.08	0.24	0.45	0.65	1.1	1.6				
最大总重t	0.4	0.32	0.96	1.8	2.6	4.4	6.4	12.8			
驱动轮数量	4										
电机类型	无刷伺服电机										
越障能力 (悬挂行程)	±15mm				±20mm						
地面最大受压 (压强)	11Mpa										
移动特性											
最小转弯半径	0m										
满载行走速度	0~0.5m/s										
行走可调精度	±1mm										
升降可调精度	±2mm										
运动功能	360°任意方向平移 (含直行、斜行、横移)、转弯、自转及以上运动的复合运动										
环境条件											
适用地面	混凝土、自流平、硬沥青、钢板地面等										
满载爬坡能力	5%										
空载爬坡能力	>20% (需考虑地面与车架的干涉)										
防护等级	IP54										
工作环境	温度: -15~+45°C; 湿度: 0~95%, 无凝露						温度: -15~+45°C; 湿度: 0~95%, 无凝露				
储存环境	温度: -20~+50°C; 湿度: 0~95%, 无凝露						温度: -20~+50°C; 湿度: 0~95%, 无凝露				
其他											
控制方式	遥控操作/自动导航/接受上位机通信指令控制										
被救援功能	手动降低、车轮解锁、外部牵引										

* 可选多车联动功能。
* 可定制任意轮系数量的整车。
* 产品会不断改进升级, 表内参数可能存在变动。
* 多数参数未达到技术极限, 可根据您的需求调整、定制, 请与我们联系。

参数选型表										
HT*4504	HT*4508	HT*5004	HT*5008	HT*5804	HT*5808	HT*5812	HT*6604	HT*6608	HT*6612	HT*6616
2500	3400	2700	3700	3000	4200	5500	3300	4600	6000	7500
1650	2000	1800	2100	2000	2300	2600	2200	2500	2800	
500		550		630			720			
1.7	3.5	2	4	2.5	5	7.5	3.5	7	10.5	14
5.5	11	7	14	9	18	28	13	27	42	55
600		650		750			850			
150										
200							150			
2.5	4.5	3	5.5	4	7	10	5	10	15	20
5	10	6	12	8	16	25	12	24	37	50
600		650		750			850		-	-
900	600	900	600	900	600		900	600	-	-
900						600	900	600	-	-
2.5	5	3	6	4	8	13	5.5	12	-	-
5	10	6	12	8	15	22	12	22	-	-
500		550		630			720			
150				180			200			
200							150			
2	3.5	2.5	4.5	3.5	6	8	4.5	9	12	16
5	11	6	13	8	17	27	12	25	40	55
铅酸电池 / 磷酸铁锂电池										
48V150AH	48V200AH	48V150AH	48V200AH	48V200AH	48V400AH	48V600AH	48V300AH	48V600AH	72V600AH	
12h (根据工作制)										
8h 铅酸电池 /4h 锂电池 (快速充电可定制)										
AC220V/AC380V										
无刷伺服电机										
4	8	4	8	4	8	12	4	8	12	16
457.2		508		584.2			660			
1.9		2.3		3.1			4.5			
7.6	15.2	9.2	18.4	12.4	24.8	37.2	18	36	54	72
4					8		4	8		
无刷伺服电机										
±20mm							±25mm			
11Mpa										
0m										
0~0.5m/s										
±1mm										
±2mm										
360°任意方向平移 (含直行、斜行、横移)、转弯、自转及以上运动的复合运动										
混凝土、自流平、硬沥青、钢板地面等										
5%										
>20% (需考虑地面与车架的干涉)										
IP54										
温度: -15~+45°C; 湿度: 0~95%, 无凝露						温度: -15~+45°C; 湿度: 0~95%, 无凝露				
温度: -20~+50°C; 湿度: 0~95%, 无凝露						温度: -20~+50°C; 湿度: 0~95%, 无凝露				
遥控操作 / 自动导航 / 接受上位机通信指令控制										
手动降低、车轮解锁、外部牵引										

OmniRhino

差动舵轮式全向车



- 单车0~60t承载能力
- 差速轮组驱动
- 灵活的运动能力,可以直行、转弯、横移、斜移、自转及以上运动的复合运动
- 联动时的内应力可控
- 弹簧悬挂/摆式悬挂/空气悬挂
- 轮系位置布置灵活/过轨能力/公铁两用/车架自顶升

产品外形

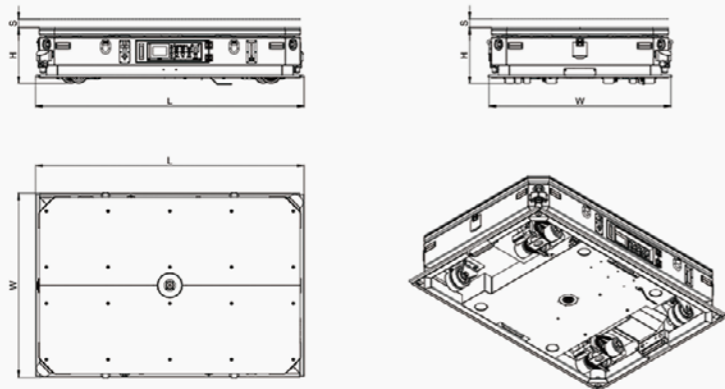

差速舵轮+万向轮

RHC / RHE / RHS



差速舵轮

RHG



运动模式

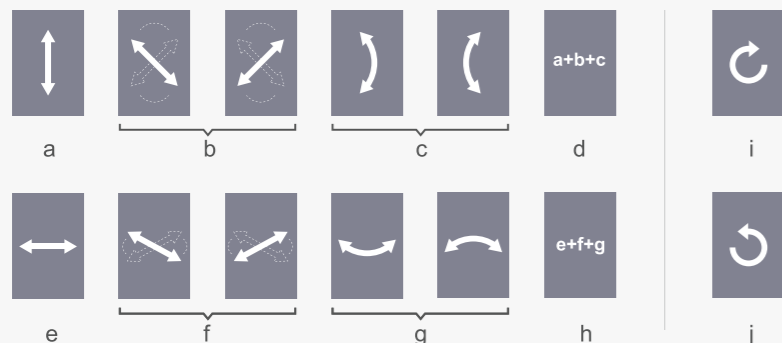

新能源汽车级锂电系统



工业遥控器



参数选型表

系列号	RHC					RHE					RHG			RHS				
产品规格																		
型号	RHC01	RHC02	RHC03	RHC05	RHC10	RHE05	RHE10	RHE20	RHE40	RHE50	RHG10	RHG20	RHG30	RHS20	RHS40	RHS60		
长 mm (L)	1600	2000	2500	3000	3500	2500	3000	4500	5000	5500	5000	5500	6000	4000	4500	5500		
宽 mm (W)	800	1000	1200	1500	1800	1200	1800	2000	2200	2600	2400	2700	3000	2300	2600	2700		
高 mm (低位状态Hmin)	290		330		450	320	420	430	500	650	600	650	750	600	650	750		
升降形式	剪叉式升降台/直动式升降台 (未包含在当前高度尺寸内)												整车车架升降					
悬挂/升降行程 mm (s)	定制												60					
载荷能力																		
设备自重 t	0.7	1.2	1.6	2.5	6	2	3	4	5	6	4	5	6	5	7	10		
承载能力 t	1	2	3	5	10	5	10	20	40	50	10	20	30	20	40	60		
电源																		
电池类型	磷酸铁锂电池																	
电池容量	48V50AH		48V100AH		48V200AH	48V100AH	48V200AH		48V400AH	48V600AH	48V300AH	48V400AH	48V600AH	48V200AH	72V400AH			
典型续航时间	12h (可根据用户需求定制)																	
满放充电时间	8h (快速充电可定制)																	
充电器供电	AC220V/AC380V																	
驱动单元																		
驱动单元数量	2					4					2							
电机类型	直流无刷伺服电机																	
悬挂类型	弹簧悬挂					摆式悬挂					空气悬挂							
车轮类型	聚氨酯实心轮										橡胶实心轮			聚氨酯实心轮				
地面最大受压	8Mpa					10Mpa					5Mpa			8Mpa				
从动单元																		
万向轮数量	4					2		全主动驱动单元						4				
万向轮型号	D100	D150	D200	D250	D268	D200	D268							D360			D400B	D400C
万向轮额定承载 t	0.8	1.6	2	2.9	5.4	2	5.4							7			12	18
悬挂类型	-					摆式悬挂								空气悬挂				
地面最大受压	10Mpa										10Mpa							
移动特性																		
最小转弯半径	0m																	
空载行走最大速度	0-0.5m/s																	
满载行走最大速度	0-0.5m/s																	
行走可调精度	±2mm																	
环境条件																		
适用地面	混凝土、自流平、硬沥青、钢板地面等																	
满载爬坡能力	5%																	
空载爬坡能力	>20% (需考虑地面与车架的干涉)																	
防护等级	IP54																	
工作环境	温度: -15~+45°C; 湿度: 0~95%, 无凝露																	
储存环境	温度: -20~+50°C; 湿度: 0~95%, 无凝露																	
控制方式																		
控制方式	遥控操作/自动导航/接受上位机通信指令控制																	
运动功能	直行、斜行、横移、自转、转弯等, 详见运动方式介绍章节																	
故障救援功能	手动降低、外部牵引 (借助地坦克)												手动降低、外部牵引 (驱动单元可提升离地, 无需借助地坦克)					

- * 可选多车联动功能。
- * 可定制任意轮系数量的整车。
- * 产品会不断改进升级, 表内参数可能存在变动。
- * 多数参数未达到技术极限, 可根据您的需求调整、定制, 请与我们联系。

OmniTitan

A-Titan轮式全向车



- 单车0~500t承载能力
- 新能源汽车级锂电系统
- 灵活的运动能力，可以直行、转弯、横移、斜移、自转及以上运动的复合运动
- 自顶升式差速舵轮，整车车体升降
- 适应室内外的雨、雪、低温环境
- 强大的越障能力

TA / TB轮系



TR轮系



新能源汽车级锂电系统



工业遥控器

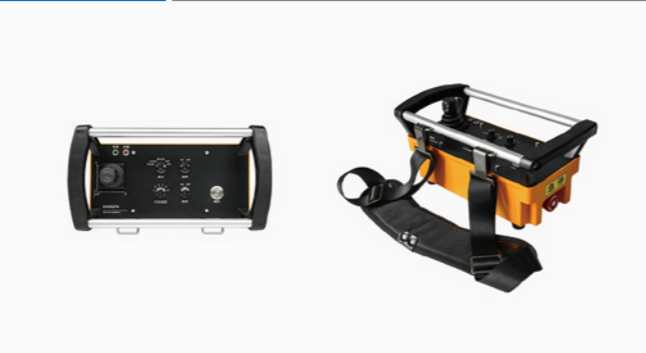

运动模式

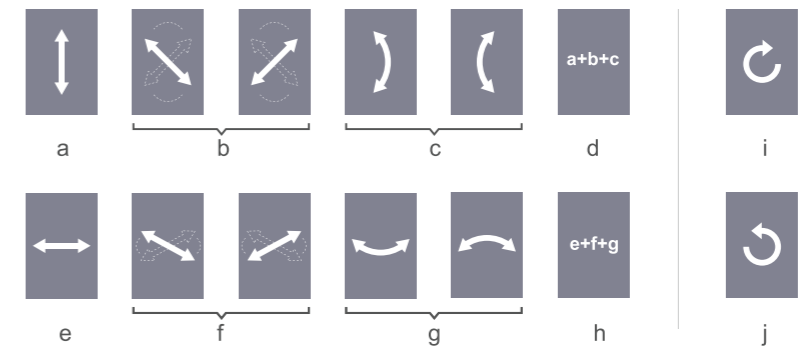

产品外形

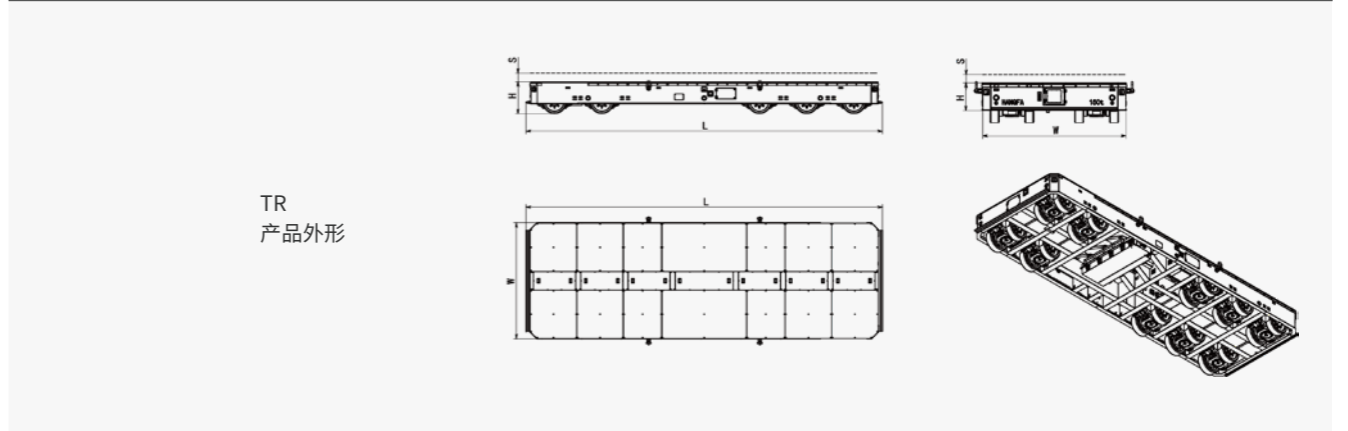
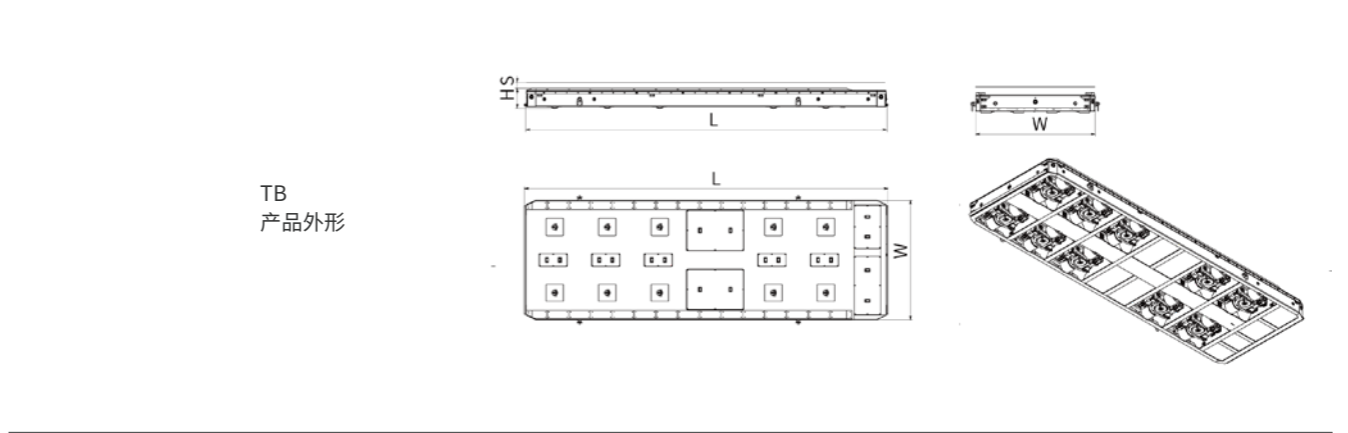
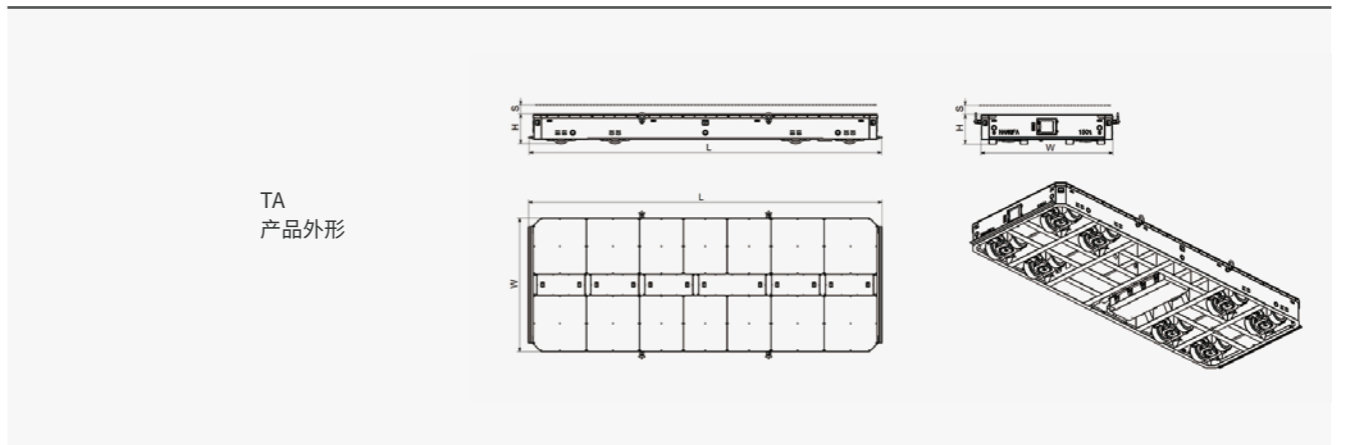

参数选型表															
系列号	TA														
产品规格															
型号	TA24	TA40	TA60	TA80	TA100	TA150	TA200	TA250	TA300	TA180	TA270	TA360	TA450	TA540	TA720
长mm (L)	3000	4000	5000	6000	5500	6500	7500	9000	11000	6000	7000	8500	10000	12000	16000
宽mm (W)	1700	2000			2500				3000						
高mm (低位状态Hmin)	450	530			670				770						
升降形式	整车车架升降														
悬挂/整机自顶升行程mm s	150					200									
载荷能力															
最大总重t	24	40	60	80	100	150	200	250	300	180	270	360	450	540	720
设备自重t	3	5	6	7	8	12	16	22	28	15	20	27	35	43	60
额定承载t	20	30	50	70	80	120	160	200	240	140	200	270	340	400	500
电源															
电池类型	磷酸铁锂电池														
电池容量kWh	10	25			30	60	90		56	110		170		220	
典型续航时间	12h(可根据用户需求定制)														
满放充电时间	8h(快速充电可定制)														
充电器供电	AC220V/AC380V														
驱动单元															
驱动单元数量	4	4	6	8	4	6	8	10	12	4	6	8	10	12	16
单元型号	A06	A10			A25				A45						
轮直径mm	250	310			457				500						
单元额定承载t	6	10			25				45						
电机类型	交流伺服电机														
悬挂/自顶升类型	液压独立型														
车轮类型	聚氨酯														
地表最大受压	10Mpa														
移动特性															
最小转弯半径	0m														
行走速度范围	0-30m/min														
满载坡道行走速度	0-20m/min														
升降速度	60-200mm/min														
行走可调精度	±2mm														
升降可调精度	±1mm														
运动功能	直行、斜行、横移、自转、转弯等, 详见运动方式介绍章节														
环境条件															
适用地面	混凝土、自流平、钢板地面等														
满载爬坡能力	5%														
空载爬坡能力	>20%(需考虑地面与车架的干涉)														
防护等级	IP54														
工作环境	温度: -15~+45°C;湿度: 0~95%, 无凝露														
储存环境	温度: -20~+50°C;湿度: 0~95%, 无凝露														
其他															
控制方式	遥控操作/自动导航/接受上位机通信指令控制														
被救援功能	手动升降、外部牵引(借助地坦克)														
其他功能	夜间照明、重量测量、重心位置测量、超载报警、偏载报警														

- * 可选多车联动功能。
- * 可定制任意轮系数量的整车。
- * 产品会不断改进升级, 表内参数可能存在变动。
- * 多数参数未达到技术极限, 可根据您的需求调整、定制, 请与我们联系。

参数选型表																
TB								TR								
TB80	TB120	TB160	TB240	TB320	TB400	TB480	TB560	TR40	TR60	TR80	TR100	TR150	TR200	TR250	TR300	TR400
4000	5000	5000	6500	8000	9000	10000	11000	5500	7000	8500	6500	8000	10000	12000	14000	17000
2000		2400						2600			3400					
320		420						750			1100					
整车车架升降																
80		100						300								
80	120	160	240	320	400	480	560	40	60	80	100	150	200	250	300	400
4	6	6	9	12	16	20	24	7	10	12	12	17	24	30	35	40
70	110	150	225	300	375	450	520	30	45	60	80	120	160	200	240	320
磷酸铁锂电池																
10	20	25	60			90	120	30	60	56	110		170		220	
12h(可根据用户需求定制)																
8h(快速充电可定制)																
AC220V/AC380V																
4	6	4	6	8	10	12	14	4	6	8	4	6	8	10	12	16
B20		B40						R10			R25					
250		310						559			848					
20		40						10			25					
交流伺服电机								交流伺服电机								
液压独立型																
聚氨酯								橡胶								
15Mpa								5Mpa								
0m								0m								
0-20m/min								0-40m/min								
0-10m/min								0-20m/min								
60-200mm/min																
±2mm																
±1mm																
直行、斜行、横移、自转、转弯等, 详见运动方式介绍章节																
混凝土、自流平、钢板地面等								混凝土、自流平、钢板、沥青、硬土地面等								
3%								10%								
>10%(需根据实际考虑应用地面与车架的干涉)								>20%(需根据实际考虑应用地面与车架的干涉)								
IP54																
温度: -15~+45°C;湿度: 0~95%, 无凝露																
温度: -20~+50°C;湿度: 0~95%, 无凝露																
遥控操作/自动导航/接受上位机通信指令控制																
手动降低、外部牵引(借助地坦克)																
夜间照明、重量测量、重心位置测量、超载报警、偏载报警																

OmniAnt

转向舵轮式全向车



- 单车0~30t承载能力
- 转向舵轮单元驱动
- 灵活的运动能力，可以直行、转弯、横移、斜移、自转及以上运动的复合运动
- 可定制1.5m/s高速版本

产品外形

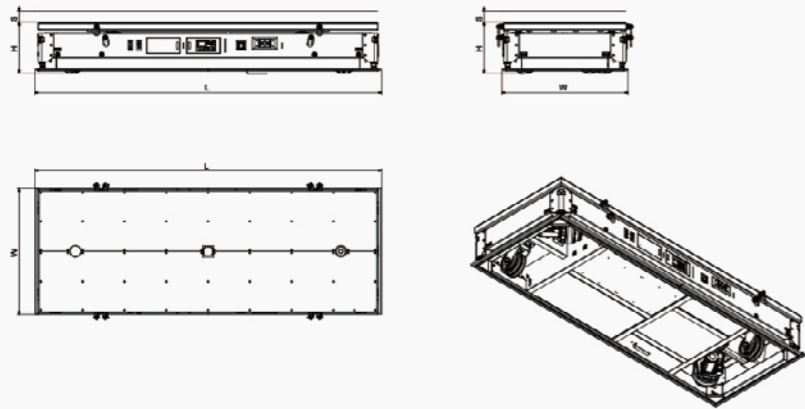

转向舵轮+万向轮



新能源汽车级锂电系统



运动模式

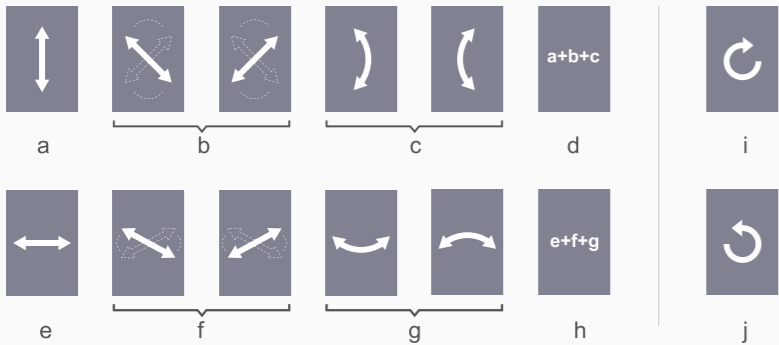

工业遥控器



参数选型表

系列号		ANT				
产品规格						
型号	AN02	AN05	AN10	AN20	AN30	
长mm (L)	2000	2500	3000	3500	4000	
宽mm (W)	1300	1500	1800	2000	2100	
高mm (低位状态Hmin)	400	470	500	600	650	
升降形式	剪叉式升降台/直动式升降台 (未包含在当前高度尺寸内)					
悬挂/升降行程mm (S)	定制					
载荷能力						
设备自重t	1	2	3	5	6	
承载能力t	2	5	10	20	30	
电源						
电池类型	磷酸铁锂电池					
电池容量	48V50AH	48V100AH	48V200AH	72V200AH		
典型续航时间	12h (可根据用户需求定制)					
满放充电时间	8h (快速充电可定制)					
充电器供电	AC220V/AC380V					
驱动单元						
驱动单元数量	2					
电机类型	直流无刷伺服电机					
悬挂类型	摆式悬挂					
地面最大受压	10Mpa					
从动单元						
万向轮数量	2					
万向轮型号	D150	D200	D268	D360	D400B	
万向轮额定承载t	1.6	2	5.4	7	12	
悬挂类型	摆式悬挂					
地面最大受压	10Mpa					
移动特性						
最小转弯半径	0m					
空载行走最大速度	0-0.5m/s					
满载行走最大速度	0-0.5m/s					
行走可调精度	±2mm					
环境条件						
适用地面	混凝土、自流平、硬沥青、钢板地面等					
满载爬坡能力	5%					
空载爬坡能力	>20% (需考虑地面与车架的干涉)					
防护等级	IP54					
工作环境	温度: -15~+45°C; 湿度: 0~95%, 无凝露					
储存环境	温度: -20~+50°C; 湿度: 0~95%, 无凝露					
控制方式						
控制方式	遥控操作/自动驾驶/接受上位机通信指令控制					
运动功能	直行、斜行、横移、自转、转弯等, 详见运动方式介绍章节					
故障救援功能	手动降低、外部牵引 (借助地坦克)					

* 可选多车联动功能。
 * 可定制任意轮系数量的整车。
 * 产品会不断改进升级, 表内参数可能存在变动。
 * 多数参数未达到技术极限, 可根据您的需求调整、定制, 请与我们联系。

P系列 桥式运输车



- 单车承载能力0~60t
- 3D雷达+北斗RTK导航
- 时速可达10km/h
- 新能源汽车电源系统，600V平台
- 汽车级橡胶轮胎
- 室外导航、安全系统，适应室外的雨、雪、低温环境

产品外形

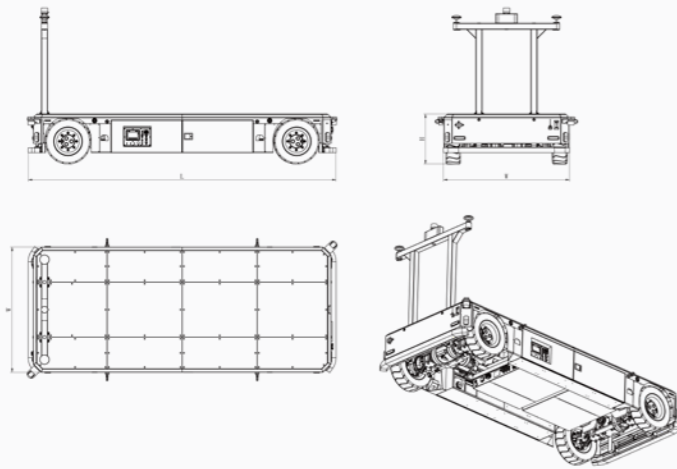

汽车级橡胶轮胎

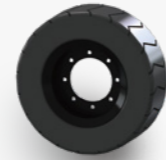

车桥

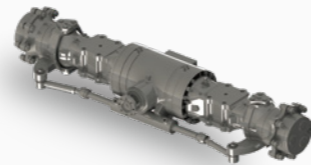

新能源汽车级电机、电池、充电桩

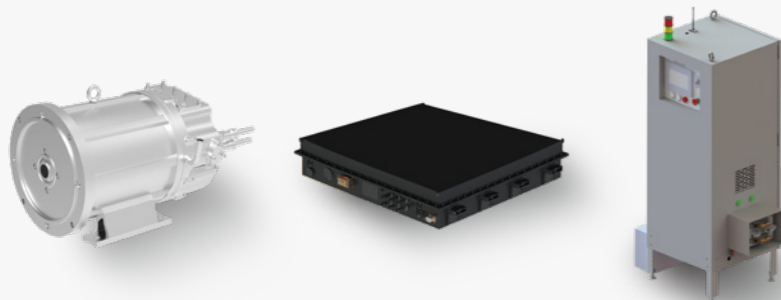

室外导航、安全系统

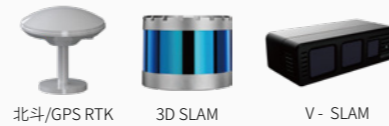

运动模式

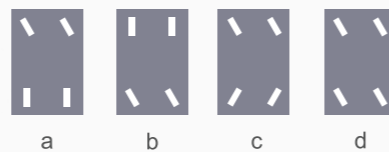

参数选型表

系列号	P		
产品规格			
型号	P10	P25	P60
长mm (L)	5000	6500	8000
宽mm (W)	2000	2500	3000
高mm (低位状态Hmin)	800	1000	1500
升降形式	可定制升降台 (未包含在当前高度尺寸内)		
升降行程	定制		
载荷能力			
设备自重t	4	6	10
承载能力t	10	25	60
电源			
电池类型	磷酸铁锂电池		
电池容量kWh	56	110	170
典型续航里程	50km (基于空载满载各半的综合工况)		
快/慢充电时间	2h / 8h		
充电器供电	AC380V		
驱动			
驱动单元数量	双桥转向, 后桥驱动		
电机类型	永磁同步电机		
悬挂类型	摆式悬挂		
车轮类型	橡胶实心轮胎/橡胶充气轮胎		
地面最大受压	5Mpa		
移动特性			
最小转弯半径m	5	6.5	7.5
行驶速度	0-10km/h		0-6km/h
运动功能	直行、斜行、转弯等, 详见运动功能介绍章节		
环境条件			
适用地面	混凝土、自流平、沥青、钢板地面等		
满载爬坡能力	5%		
空载爬坡能力	> 20% (需考虑地面与车架的干涉)		
防护等级	IP55 (可适应室外雨天工作环境)		
工作环境	温度: -25~+45°C; 湿度: 0~95%, 无凝露		
储存环境	温度: -20~+50°C; 湿度: 0~95%, 无凝露		
控制方式			
控制方式	遥控操作/自动导航/接受上位机通信指令控制		
故障救援功能	外部牵引		

* 产品会不断改进升级, 表内参数可能存在变动。

* 多数参数未达到技术极限, 可根据您的需求调整、定制, 请与我们联系。

WH 风电叶片转运车



- 联动30~120t承载能力
- 联动距离可达80m，适应长达130m的叶片
- 可回转的载物台，使叶片被运输时只受轴向力
- 最高速度可达1m/s
- 联动时的内应力可控
- 底盘浮动设计，可以适应大面积场地的排水斜度和进出车间的斜坡

产品外形



WH 运动模式

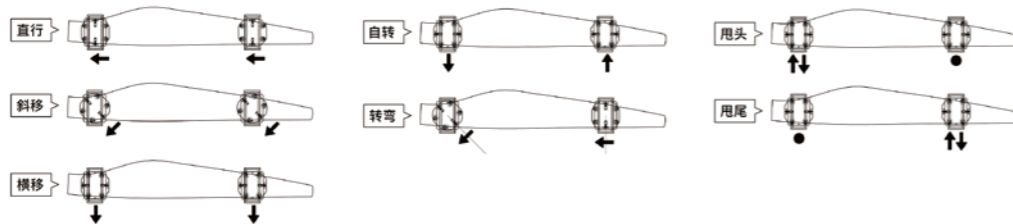

参数选型表

系列号	WH				
产品规格					
型号 (一套两台)	WH30	WH40	WH60C	WH60	WH120
外形回转直径mm	2700		3200	4200	4500
外形(高)mm (低位状态)	560		660		810
顶升行程mm	120		150		
载物平台尺寸mm	1600×1200		1900×1600	2600×1850	2700×2200
载荷能力					
额定承载t (单车)	15	20	30		60
额定承载t (联动双车)	30	40	60		120
设备自重t (单车)	5	5	6.5	8.5	10
电源					
电池类型	免维护铅酸电池		磷酸铁锂电池		
电池容量kWh	14.4		25		50
典型续航里程 (20°C, 满载、空载各半)	8Km	7Km	8Km		8Km
典型续航时间	两个班次				
充电时间	8h		4h		
待机时间	>72h				
充电器供电 (其他电压可选配)	AC220V/AC380V				
基本特性					
双车联动最大中心距	80m				
驱动轮直径mm	330		410		500
冰雪地车轮	可选配				
驱动电机类型	无刷伺服电机				
悬挂/自顶升类型	独立液压升降台				
地面最大承压	10Mpa				
动作特性					
最小转弯半径	0m				
额定行走速度	0~0.85m/s		0~0.6m/s		
最高行走速度	0~1m/s				
举升速度	300mm/min		200mm/min		
行走可调精度	±3mm				
升降可调精度	±5mm				
环境条件					
适用地面	混凝土、自流平、硬沥青、钢板地面等				
满载爬坡能力 (T1)	2% (连续坡道。例如大面积场地的排水斜度)				
满载爬坡能力 (T2)	6% (短距离坡道。例如进出车间的短距离斜坡)				
空载爬坡能力	20% (需考虑地面与车架的干涉或设置过渡弧)				
防护等级	IP54 (可适应在小雨、小雪天的室外工作)				
工作环境	温度: -30~+50°C; 湿度: 0~95%, 无凝露				
储存环境	温度: -15~+50°C; 湿度: 0~95%, 无凝露				
其他					
控制方式	遥控操作				
单车运动功能	直行、自转、转弯				
双车联动运动功能	直行、斜行、横移、自转、转弯、甩头、甩尾及复合运动				
测重功能	重量测量、超载报警				
故障救援功能	升降台手动降低、车轮解锁				
其他功能	夜间运行照明、喇叭				

- * 可选多车联动功能。
- * 可定制任意轮系数量的整车。
- * 产品会不断改进升级，表内参数可能存在变动。
- * 多数参数未达到技术极限，可根据您的需求调整、定制，请与我们联系。

Omni Wheel / Mecanum Wheel



全向轮/麦克纳姆轮

	<p>QL系列 全向轮 90°</p> <p>外径(mm): 50.8(2") ~ 203.2(8") 承载范围: 5kg ~ 30kg 小轮材质: 橡胶 轮毂材质: 铝合金</p>	<p>主要型号:</p> <p>QL-05A/B QL-08 QL-10 QL-13 QL-15 QL-20</p>
	<p>CL系列 全向轮 90°</p> <p>外径(mm): 101.6(3") ~ 127(5") 承载范围: 5kg ~ 50kg 小轮材质: 橡胶 轮毂材质: 钢</p>	<p>主要型号:</p> <p>CL-10 CL-13</p>
	<p>QLM系列 全向轮 90°</p> <p>外径(mm): 120 ~ 406.4 承载范围: 50kg ~ 2000kg 小轮材质: 橡胶/聚氨酯 轮毂材质: 铝合金/钢</p>	<p>主要型号:</p> <p>QLM-12 QLM-15 QLM-20s QLM-20 QLM-24 QLM-25 QLM-28 QLM-31 QLM-36 QLM-40 QLM-40A</p>
	<p>PLM系列 全向轮 90°</p> <p>外径(mm): 203.2(8") 承载范围: 0kg ~ 80kg 小轮材质: 聚氨酯 轮毂材质: 铝合金</p>	<p>主要型号: PLM-20</p>
	<p>QMA系列 麦克纳姆轮 45°</p> <p>外径(mm): 101.6(4") ~ 203.2(8") 承载范围: 30kg ~ 40kg 小轮材质: 橡胶 轮毂材质: 钢</p>	<p>主要型号:</p> <p>QMA-10 QMA-15 QMA-20</p>
	<p>CMA系列 麦克纳姆轮 45°</p> <p>外径(mm): 156.5 ~ 660.4 承载范围: 100kg ~ 4500kg 小轮材质: 聚氨酯 轮毂材质: 铝合金/钢</p>	<p>主要型号:</p> <p>CMA-15 CMA-20 CMA-20A CMA-25 CMA-31 CMA-36 CMA-40 CMA-45 CMA-50 CMA-58 CMA-66</p>
	<p>HMA系列 麦克纳姆轮 45°</p> <p>外径(mm): 310 ~ 406.4(16") 承载范围: 600kg ~ 1500kg 小轮材质: 聚氨酯 轮毂材质: 铝合金/钢</p>	<p>主要型号:</p> <p>HMA-31 HMA-40</p>

Research-Platform

科研级平台

领航系列平台

	三轮全向平台	四轮全向平台	两轮差动平台	四轮差动平台	覆带式平台
产品图					
外形尺寸	560x600x241(mm)	672x481x241(mm)	494x490x219(mm)	698x598x279(mm)	720x559x283(mm)
承载能力	50kg	50kg	50kg	80kg	80kg

指南针系列平台

	三轮全向平台	四轮全向平台	两轮差动平台	四轮差动平台	覆带式平台
产品图					
外形尺寸	369x400.5x110(mm)	450x330x115(mm)	342x370x115.5(mm)	352.4x370x135(mm)	400x354x108(mm)
承载能力	20kg	20kg	20kg	30kg	30kg

发现系列平台

	三轮全向平台	四轮全向平台	两轮差动平台	四轮差动平台	覆带式平台
产品图					
外形尺寸	365.5x400.2x109(mm)	359x313.5x114(mm)	231x314x120(mm)	301.6x308x112(mm)	325x285x100(mm)
承载能力	10kg	10kg	10kg	15kg	15kg

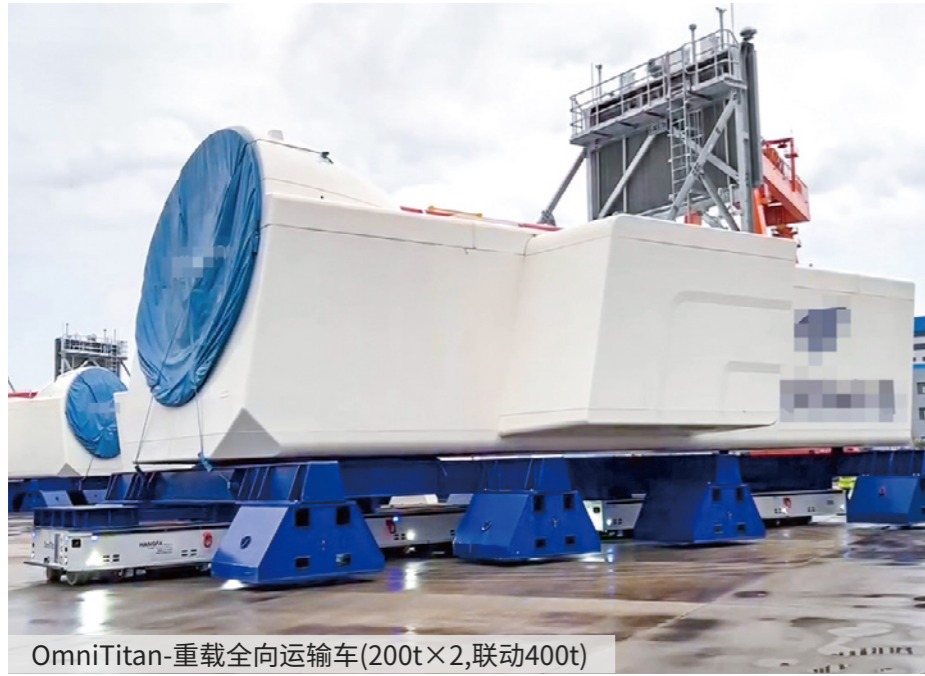

OmniTitan-重载全向运输车(200t×2,联动400t)



OmniTitan-重载全向运输车(200t)



OmniTitan-重载全向运输车(200t)



OmniTitan-重载全向运输车(200t)



OmniTitan-重载全向运输车(200t)



OmniTitan-重载全向运输车(110t)

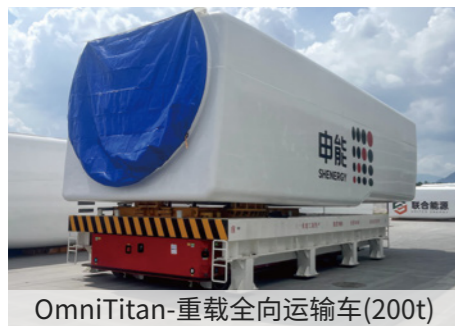

OmniTitan-重载全向运输车(200t)



OmniTitan-重载全向运输车(80t)



OmniTitan-重载全向运输车(150t)



OmniTitan-重载全向运输车(50t)



OmniTitan-重载全向运输车(80t)



OmniTitan-重载全向运输车(80t)



WH-风电叶片联动运输车(30tx2)

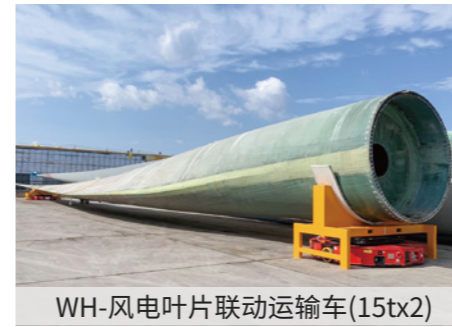

WH-风电叶片联动运输车(15tx2)

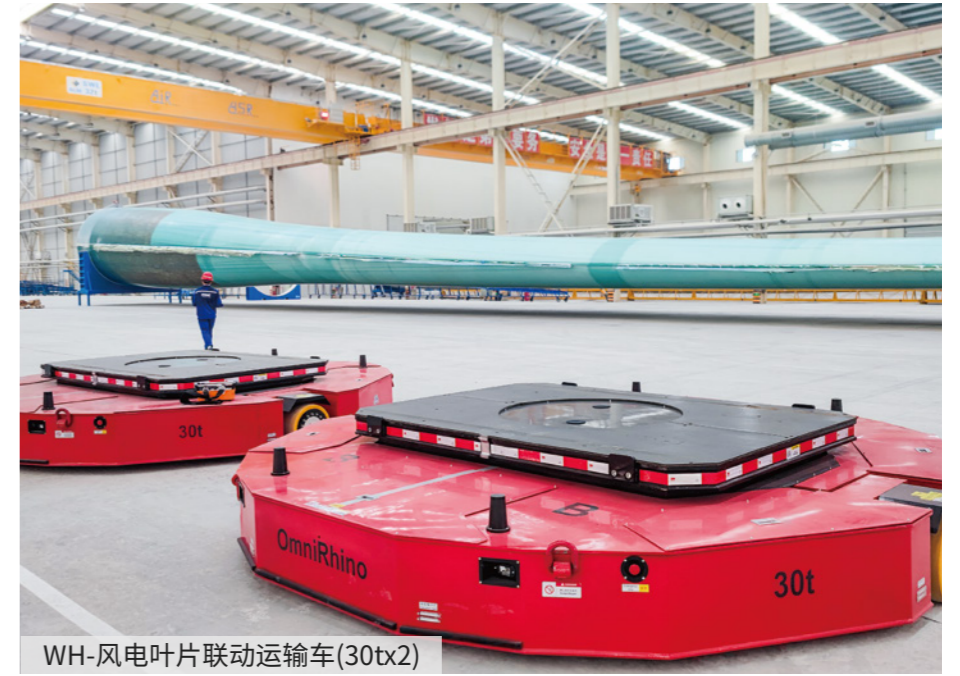

WH-风电叶片联动运输车(30tx2)

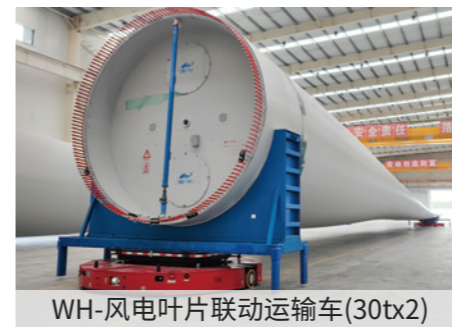

WH-风电叶片联动运输车(30tx2)

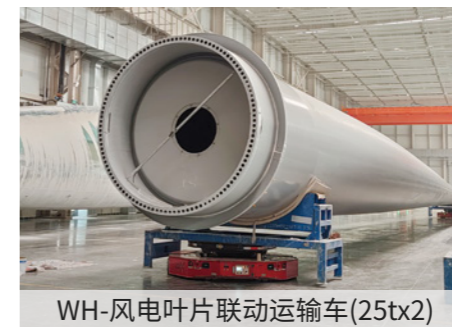

WH-风电叶片联动运输车(25tx2)

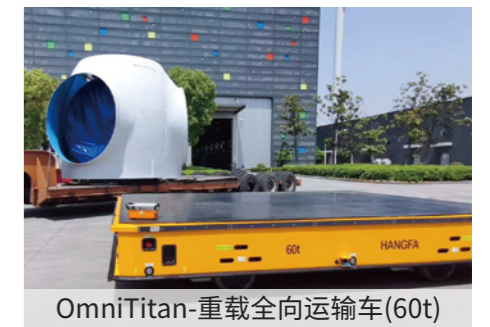

OmniTitan-重载全向运输车(60t)



WH-风电叶片联动运输车(30tx2)



WH-风电叶片联动运输车(25tx2)

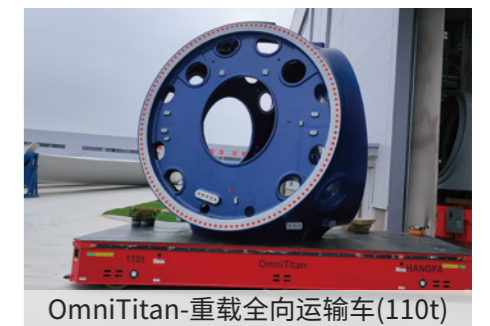

OmniTitan-重载全向运输车(110t)

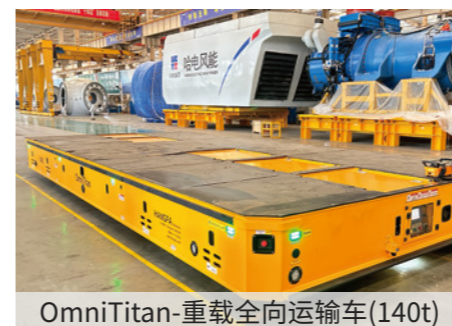

OmniTitan-重载全向运输车(140t)



OmniTitan-重载全向运输车(80t)



OmniTitan-重载全向运输车(200t)

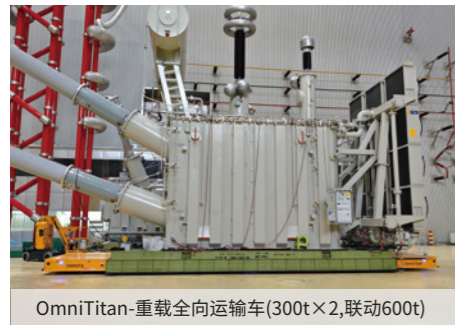

OmniTitan-重载全向运输车(300t×2,联动600t)



OmniTitan-重载全向运输车(400t)

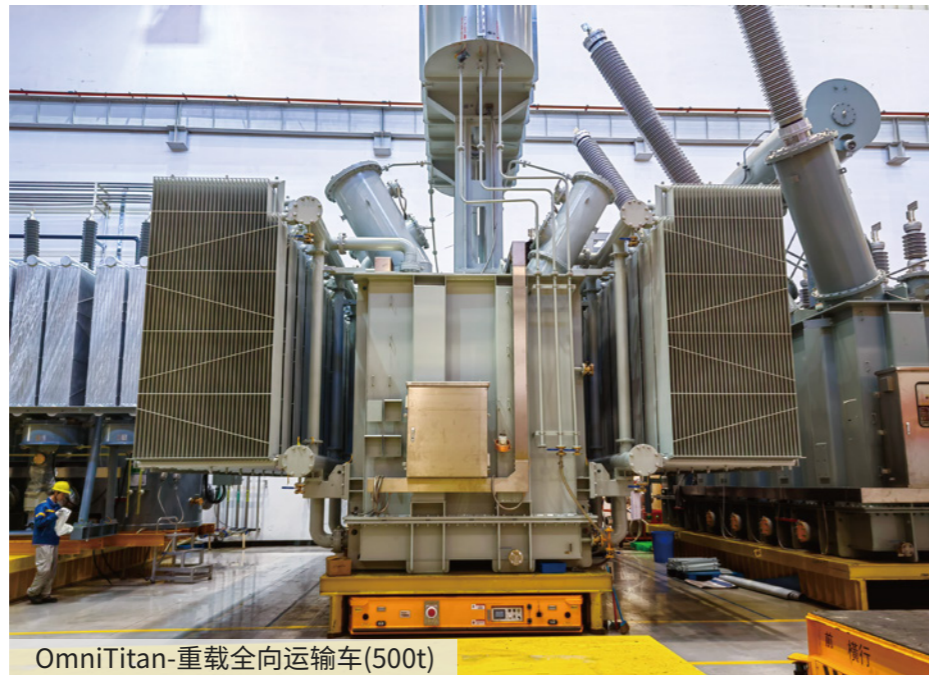

OmniTitan-重载全向运输车(500t)



OmniTitan-重载全向运输车(300t)



OmniTitan-重载全向运输车(300t)



OmniTitan-重载全向运输车(300t)



OmniTitan-重载全向运输车(300t)



OmniTitan-重载全向运输车(300t)



OmniTitan-重载全向运输车(150t)



OmniTitan-重载全向运输车(300t)

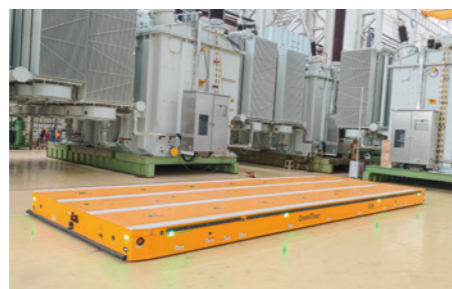

OmniTitan-重载全向运输车(500t)



OmniTitan-重载联动全向运输车(160t)



OmniTitan-重载全向运输车(150t)



OmniTitan-重载全向运输车(150t×2,联动300t)



OmniTitan-重载全向运输车(100t)



OmniTitan-重载全向运输车(80t)



OmniTitan-重载全向运输车(400t)



OmniTitan-重载全向运输车(30t)

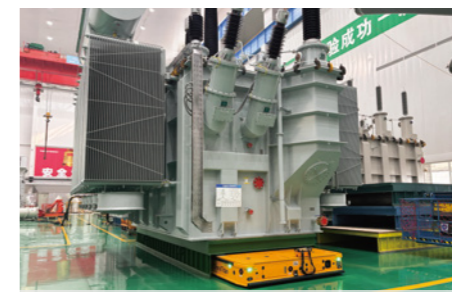

OmniTitan-重载全向运输车(300t)



OmniTitan-重载全向运输车(300t)



OmniTitan-重载全向运输车(65t)



OmniTitan-重载全向运输车(50t)



OmniTitan-重载全向运输车(18t)



OmniTurtle-双车联动列车移动平台(25tx2)



OmniRhino-双车联动运输车(30tx2)



OmniRhino-双车联动运输车(25tx2)



OmniRhino-双车联动运输车(15tx2)



OmniTurtle-集装挂轨麦轮车(40t)



OmniRhino-联动运输车(30tx2)



OmniTurtle-重载全向运输车(5t)



OmniTurtle-重载联动运输车(10tx2)



空轨牵引车(100t)



OmniRhino-转向架自动生产线(13t)



OmniRhino-重载全向运输车(4t)



OmniRhino-重载全向运输车(10t)



OmniTurtle-重载全向运输车(3.5t)



OmniTitan-重载全向运输车(15t)



OmniTurtle-重载全向运输车(4t)



OmniTurtle-重载全向运输车(13t)

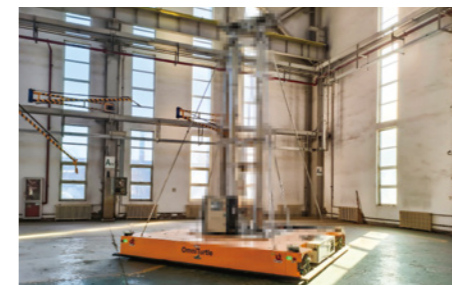

OmniTurtle-重载全向运输车(3t)



OmniTurtle-重载全向运输车(2.75t)



采棉机运输车(40t)



OmniTitan-重载全向运输车(30t)



OmniRhino-三车联动全向运输车(50tx3)



OmniTitan-重载全向运输车(50t)



OmniAnt-重载全向运输车(20t)



OmniAnt-重载全向运输车(25t)



OmniTitan-重载全向运输车(15t)



OmniRhino-重载全向运输车(10t)



OmniAnt-动力头运输AGV(20t)



OmniRhino-重载全向运输车(20t)



OmniRhino-有轨运输车(50t)



OmniRhino-重载全向运输车(6t)



OmniRhino-钛坩运输车(10t)



OmniRhino-抬包运输车(30t)



定制型拉线缆叉车AGV(8t)



OmniTitan-重载全向运输车(60t)



OmniTitan-钢卷运输车(50t)



OmniTurtle-变压器拆装平台(5t)

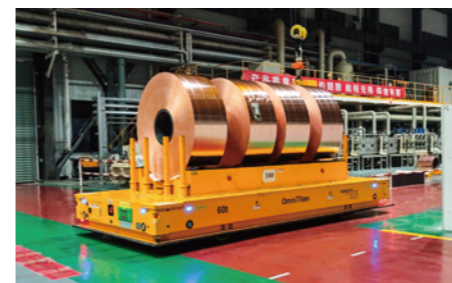

OmniTitan-重载全向运输车(60t)



OmniTitan-重载全向运输车(100t)



OmniTitan-重载全向运输车(200t)



OmniTitan-重载联动运输车(12x2t)



定制型重载运输车(4t)

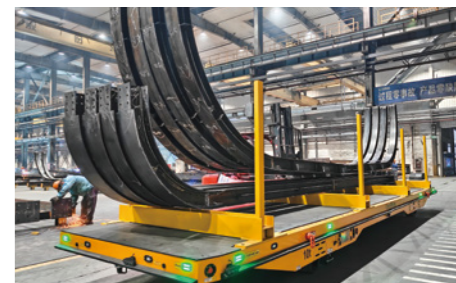

OmniRhino-重载全向运输车(10t)



OmniAnt-重载全向运输车(20t)

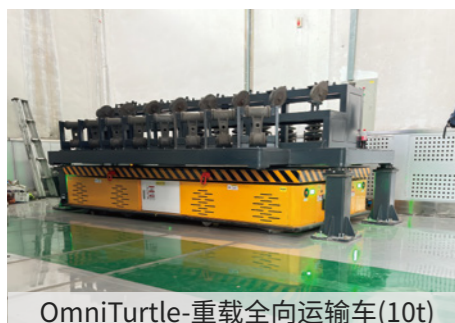

OmniTurtle-重载全向运输车(10t)

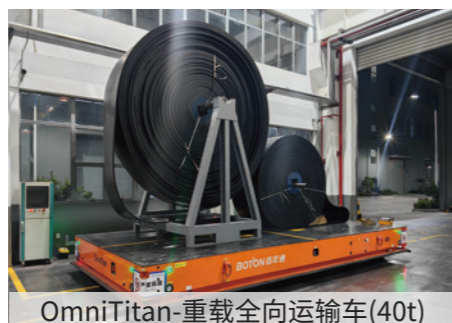

OmniTitan-重载全向运输车(40t)



OmniTitan-重载全向运输车(40t)



OmniTitan-重载全向运输车(50t)



OmniTitan-重载全向运输车(80t)



OmniTitan-重载全向运输车(30t)



OmniTurtle-重载全向运输车(10t)



OmniTurtle-重载全向运输车(5t)

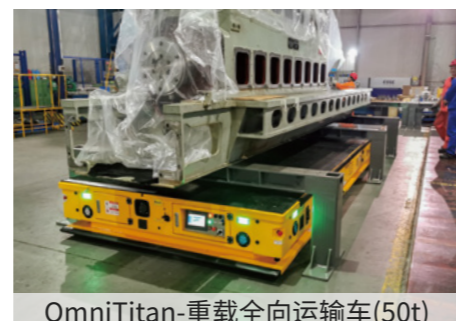

OmniTitan-重载全向运输车(50t)

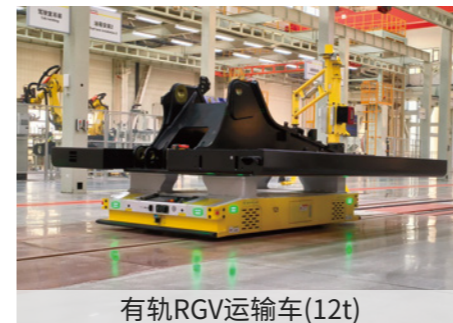

有轨RGV运输车(12t)



有轨RGV运输车(10t)



OmniAnt-运鱼AGV(2m³)



OmniTitan-重载全向运输车(30t)



OmniRhino-钻杆运输AGV(10tx2)

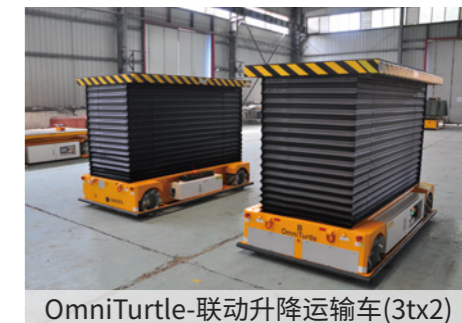

OmniTurtle-联动升降运输车(3tx2)



OmniRhino-重载全向运输车(6t)



OmniRhino-重载全向运输车(30t)

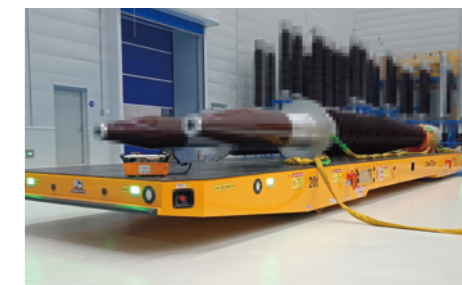

OmniTitan-重载全向运输车(20t)

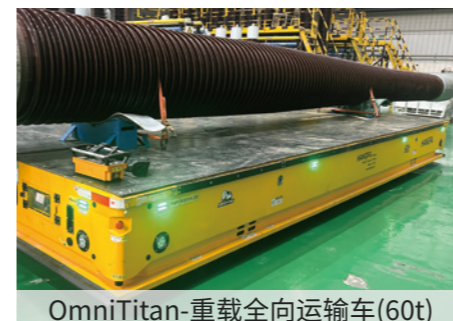

OmniTitan-重载全向运输车(60t)



OmniTurtle-重载全向运输车(10t)



OmniTitan-重载全向运输车(100t)



OmniTitan-自动导引运输AGV(30t)



OmniTurtle-重载全向运输车(6t)



OmniTitan-重载全向运输车(150t)



OmniAnt-重载全向运输车(1.5t)

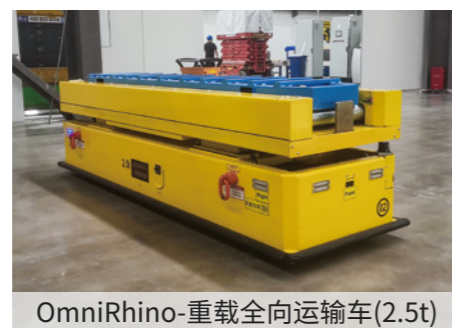

OmniRhino-重载全向运输车(2.5t)

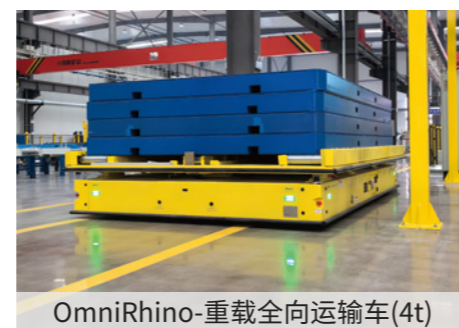

OmniRhino-重载全向运输车(4t)

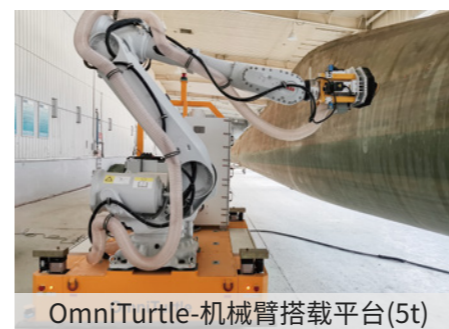

OmniTurtle-机械臂搭载平台(5t)



OmniTurtle-重载全向运输车(4t)



OmniTurtle-机械臂搭载平台(5t)



OmniTurtle-全向运输车(100kg)



OmniTurtle-机械臂搭载平台(5t)



OmniTurtle-全向移动升降平台(1.2t)



OmniRhino-重载全向运输车(2t)



定制型叉车AGV(4t)



定制型叉车AGV(15t)



定制型叉车AGV(7.5t)



OmniTurtle-全向运输车(10t)



OmniTurtle-高空作业平台(3t)